

## LSZ-10S Shotcrete machine (dry and wet mix)



## ◆ **Product Description**

LSZ-10S Shotcrete machine (dry and wet mix) is a multifunctional rotor type machine for wet and dry spraying and conveying. The materials that can be sprayed and conveyed are concrete, mortar, refractory, sand, pea gravel and crushed stone.

Compared with traditional shotcrete machines, LSZ-10S has the advantage of being lighter and more compact. In addition, LSZ-10S is equipped with a rubber sealing plate lubrication system, which can effectively reduce the wear of rubber plates, longer service life and better sealing effect.

## ◆ **Advantages and Benefits**

1. Theoretical displacement can be adjusted.
2. Easily overcome obstacles of long or high conveying distances (dry mix).
3. Less dust development.
4. Reduced rebound.
5. For concrete repair, slope stabilization, excavation support or mining.
6. Light and compact machine design.

◆ The Main Structure

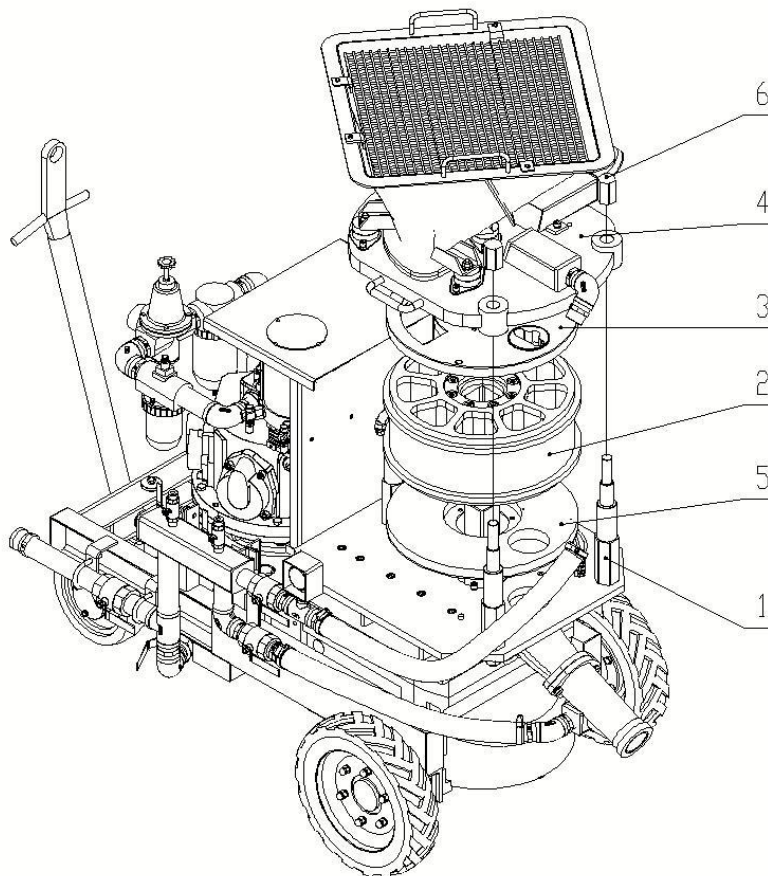

1	Modify clamp
2	Rotor
3	Upper rubber plate
4	Hopper seat
5	Lower rubber plate
6	Clamp

◆ Dimension Figure

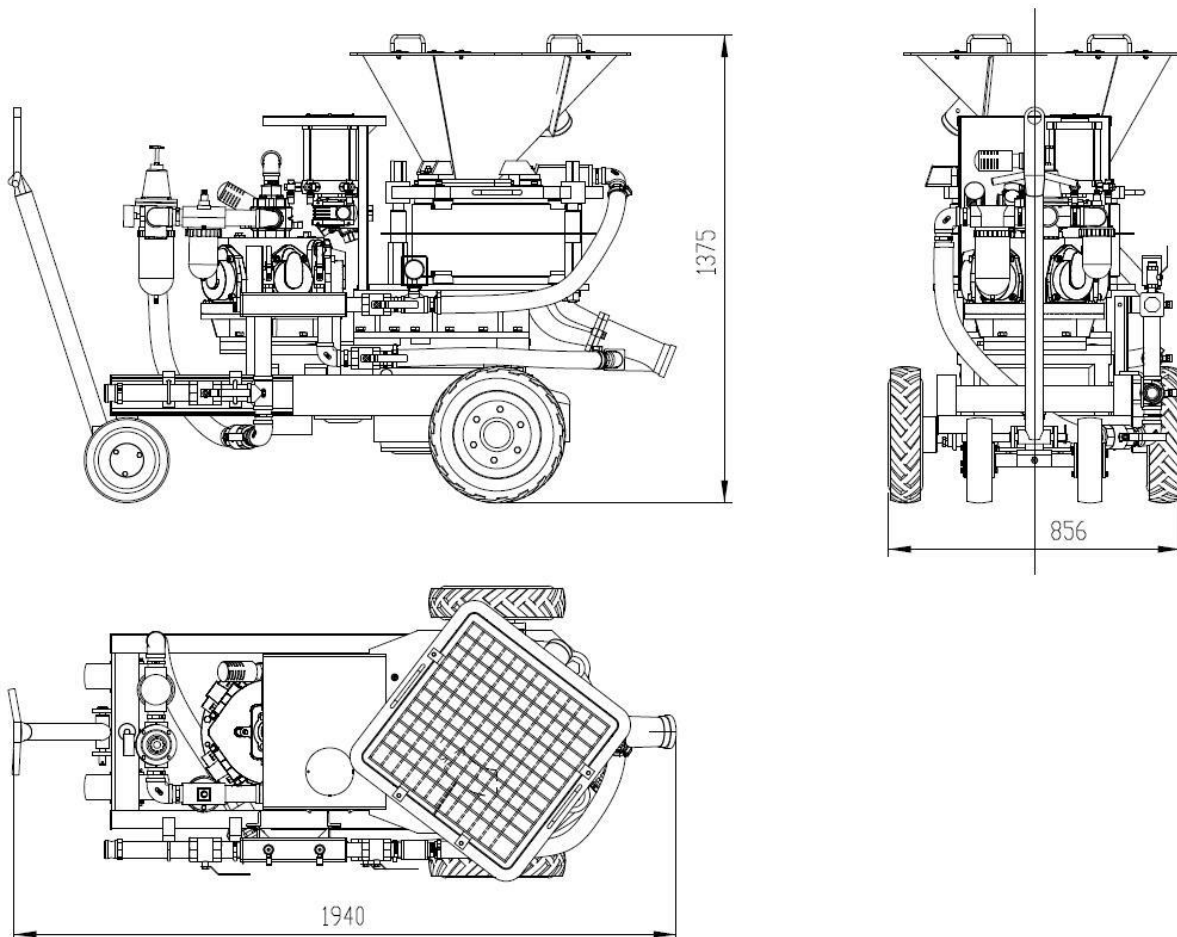

◆ **Technical Data**

Name	Data	
Machine type	Rotary machine LSZ-10S	
Process	Thin-stream	
Air motor type	TMH8A	
Air motor power	8 kw	
Air consumption	Machine	10 m <sup>3</sup> /min
	Air motor	9 m <sup>3</sup> /min
Air pressure	Machine	0.2Mpa
	Air Motor	0.63Mpa
Air motor speed	650rpm	
Rotor speed	12.3rpm	
Rotor size in liters	14.5	
Theoretical output in m <sup>3</sup> /h ①	10	
Recommended hose sizes(mm)	D64	
Max. aggregate size (mm)	20	
Max. conveying distance in m horizontal/vertical	Dry: 300/100	
	Wet: 40/15	
Dimensions in mm	Length	1940
	Height	1375
	Width	856
Weight in kg	1040 Kg	
① Based on a theoretical filling level of 100%. Prior to use or processing, always consult the current product data sheet of the products used		

◆ Detail Parts

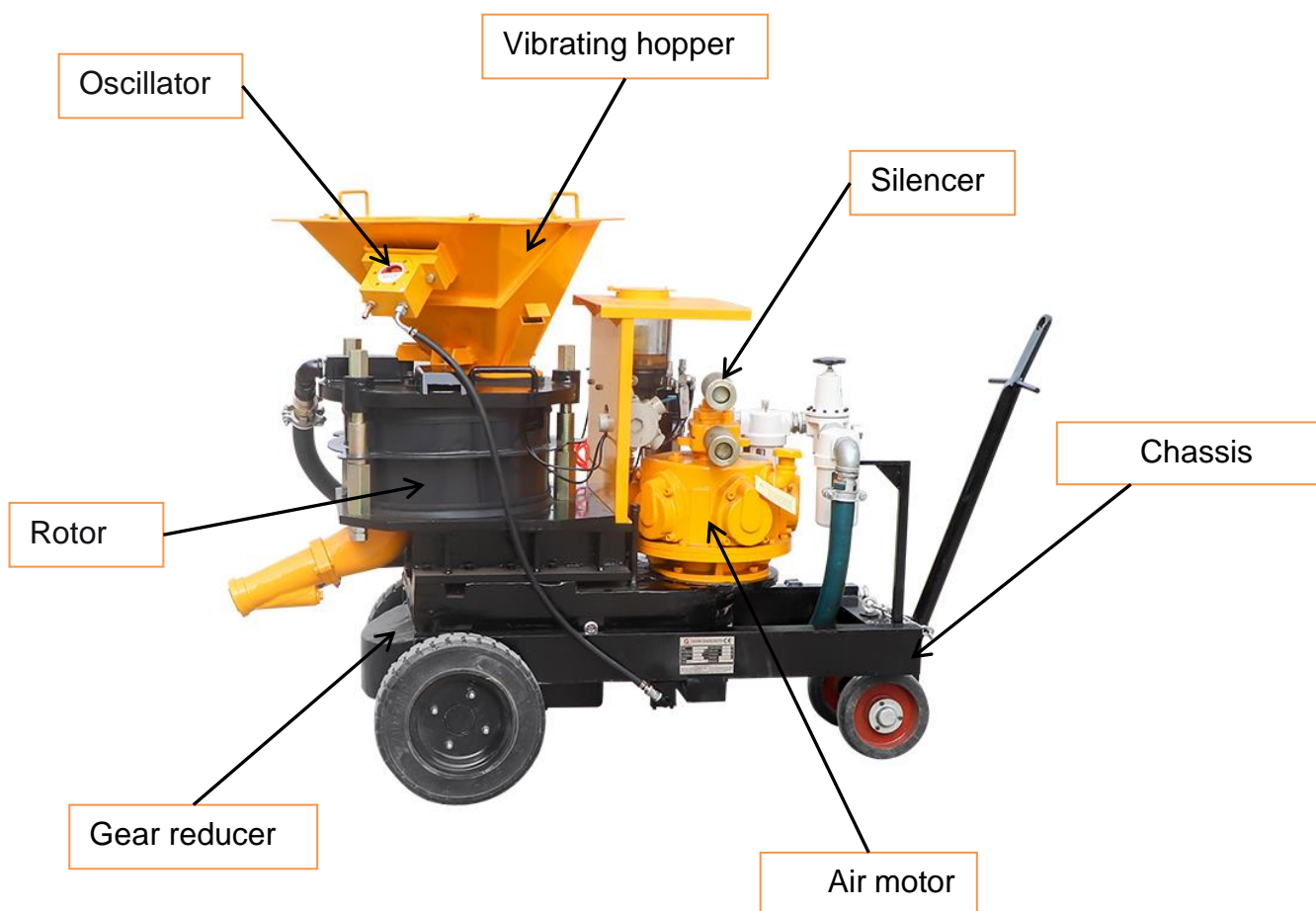

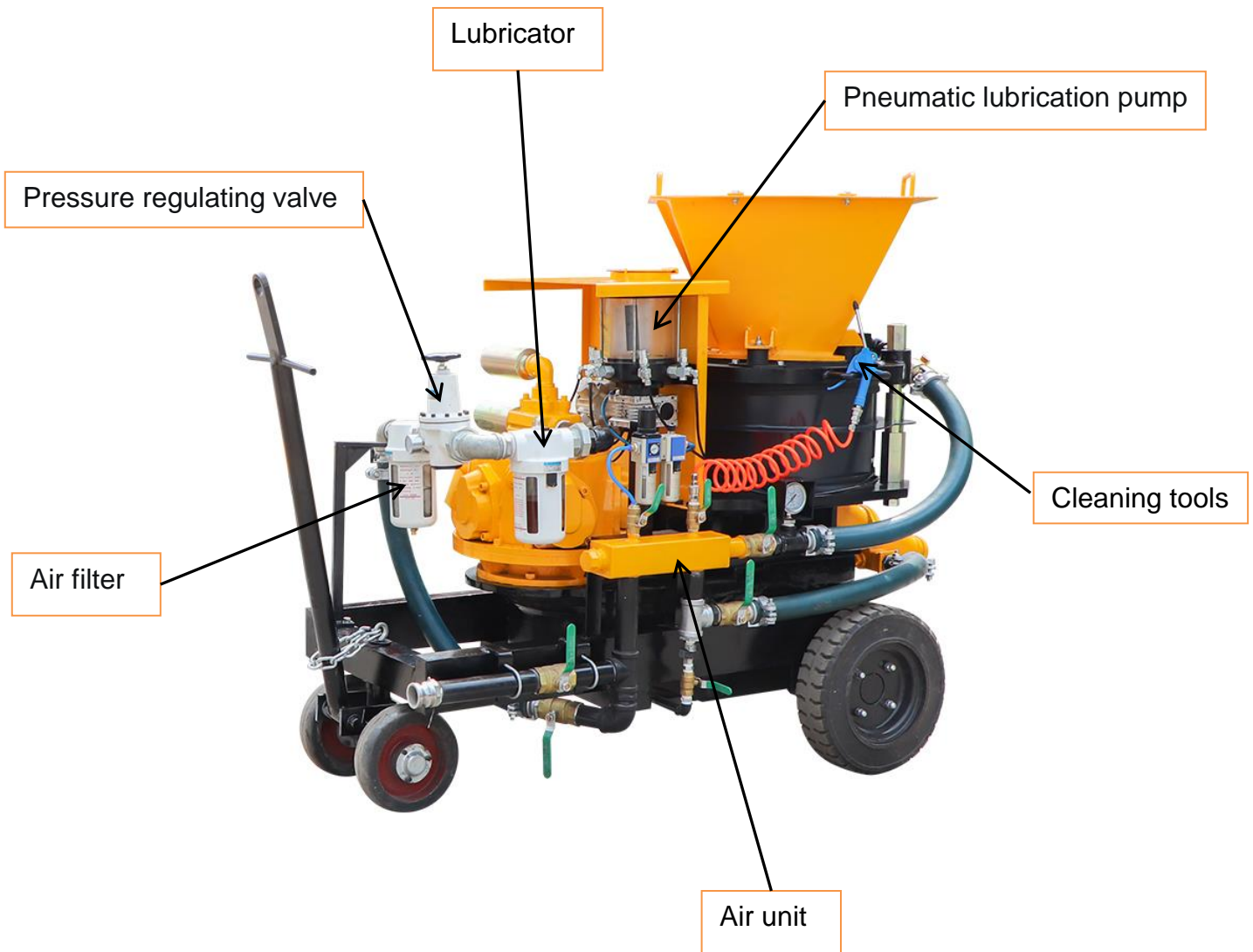

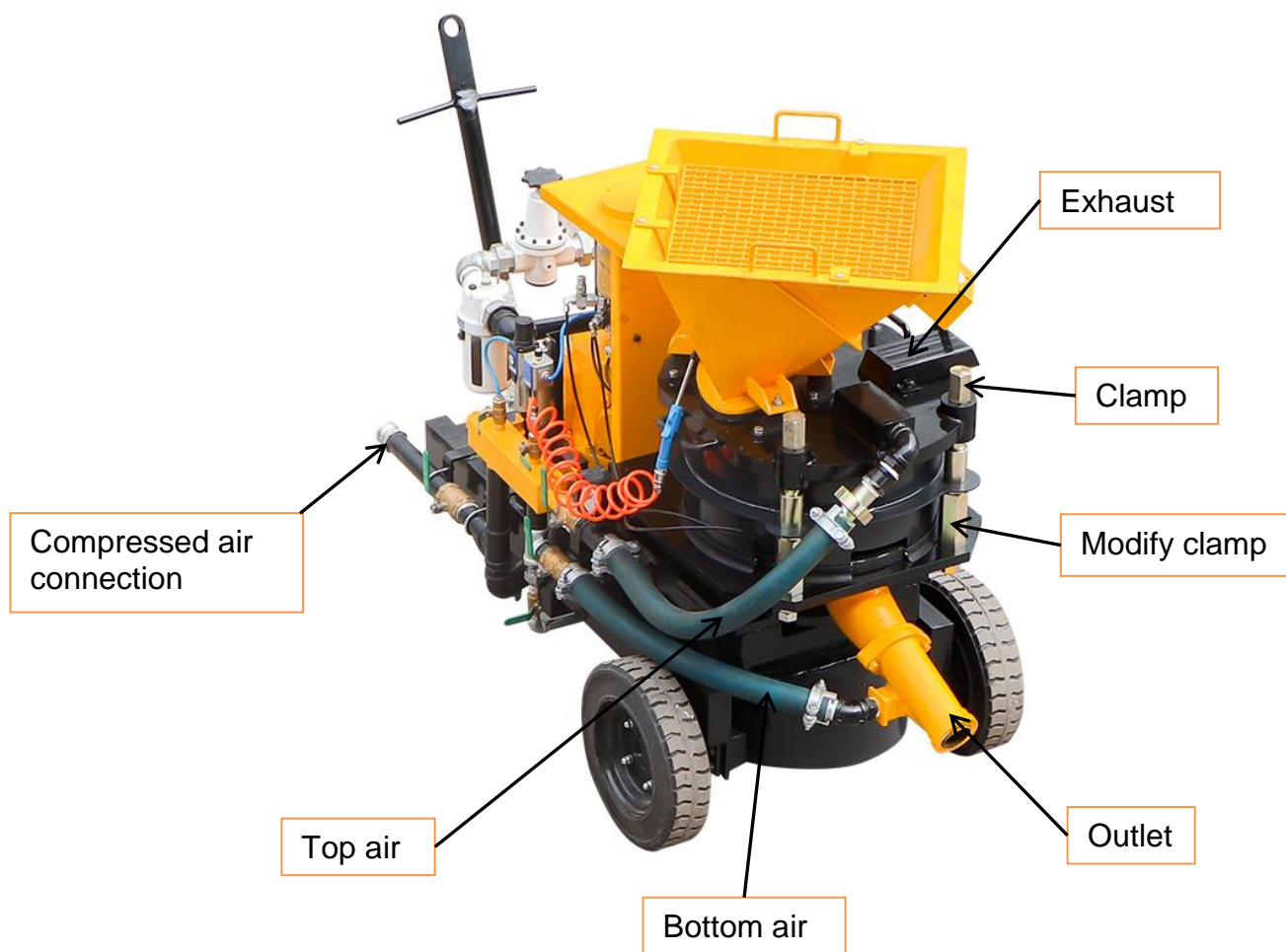

**Zhengzhou Lead Equipment Co., Ltd.**

Add: Xisihuan Ring-Road East, Tielu, Xiliu lake sub-district,  
Zhongyuan District, Zhengzhou, Henan  
Web: <https://www.leadcrete.com>  
E-Mail: [sales@leadcrete.com](mailto:sales@leadcrete.com)